

Case Study: Maltman Bungalows

Mott Smith, Principal, Civic Enterprise

Panel: Smart and Green: Could Housing Trends Bolster Sustainable Building Patterns?

NEW PARTNERS FOR SMART GROWTH CONFERENCE
FEBRUARY 1, 2012
SAN DIEGO



Civic Enterprise Development LLC

2006

2006

The housing market was booming.

2006

The housing market was booming.

Condos were going up everywhere.

But new development at higher densities
was not leading to more affordability.

But new development at higher densities
was **not leading to more affordability.**

Why not?

Parking requirements.

Parking requirements.

Parking requirements.

Also, condo projects can cost **\$25,000-\$40,000 more per door** than equivalent non-condo projects.

Also, condo projects can cost
\$25,000-\$40,000 more per door than
equivalent non-condo projects.

Why?

Why?

**Common interest subdivisions (like
condos) are tailor-made for lawsuits.**

**Then a few brilliant L.A. City Planners
decided to do something to fix this.**

ORDINANCE NO. 176354

An ordinance amending Sections 12.03, 12.09, 12.12.1, 12.21 and 12.22 of the Los Angeles Municipal Code to permit detached for-sale small lot subdivisions in commercial and multifamily residential zones.

THE PEOPLE OF THE CITY OF LOS ANGELES
DO ORDAIN AS FOLLOWS:

Section 1. Section 12.03 of the Los Angeles Municipal Code is amended by revising the definition of 'lot' to read:

LOT. A parcel of land occupied or to be occupied by a use, building or unit group of buildings and accessory buildings and uses, together with the yards, open spaces, lot width and lot area as are required by this chapter and fronting for a distance of at least 20 feet upon a street as defined here, or upon a private street as defined in Article 8 of this chapter. The width of an access-strip portion of a lot shall not be less than 20 feet at any point. In a residential planned development or an approved small lot subdivision a lot need have only the street frontage or access as is provided on the recorded subdivision tract or parcel map for the development.

Sec. 2. Subdivision 3 of Subsection A of Section 12.09 of the Los Angeles Municipal Code is amended to read:

3. Apartment houses, boarding or rooming houses, dwelling units in a small lot subdivision, or multiple dwellings on lots having a side lot line adjoining a lot in a commercial or industrial zone, provided that:

(a) The use, including the accessory buildings and uses and required yards, does not extend more than 65 feet from the boundary of the less restrictive zone which it adjoins; and

(b) The lot area per dwelling unit or guest room regulations of the RD1.5 zone shall apply to these uses.

Sec. 3. Subsection A of Section 12.12.1 is amended by adding a new subdivision 8 to read.

8. Dwelling unit or units constructed on a lot in a small lot subdivision and approved by the Advisory Agency, pursuant to Article 7 of this Chapter in conformity with the provision of 12.22 C 27 of this Code.

Small Lot
Subdivision
ordinance
takes effect in
2005.

A different take on planning:

Using ordinances to create safe passage for desirable projects in good locations.

Zone	Use	Maximum Height		Required yards			Minimum Area		Minimum Lot Width	Parking Required
		Stories	Feet	Front	Side	Rear	Per Lot	Per Dwelling Unit		

Multiple Residential

R2	Two-Family Dwellings R1 Uses, Home Occupations	Determined by Height District *10	45 ft. or *6,*10	20% lot depth; 20 ft. max., but not less than prevailing	10% lot width 50 ft.; 5 ft.; 3 ft. min.; + 1 ft. for each story over 2 nd	15 ft.	5,000 sq. ft.	2,500 sq. ft.	50 ft.	2 spaces, one covered	
RD1.5	Restricted Density Multiple Dwelling One-Family Dwellings, Two-Family Dwellings, Apartment Houses, Multiple Dwellings, Home Occupations			15 ft.	10% lot width < 50 ft.; 5 ft.; 3 ft. min.; + 1 ft. for each story over 2 nd , not to exceed 16 ft. *6		5,000 sq. ft.	1,500 sq. ft.			1 space per unit < 3 habitable rooms; 1.5 spaces per unit = 3 habitable
RD2							2,000 sq. ft.				
RD3							6,000	3,000			

The big idea:

**Townhouse density (+/- 20 du/ac)
with fee simple ownership.**

The big idea:

Townhouse density (+/- 20 du/ac)
with **fee simple ownership.**

Lower cost of development.

Lower cost of development.

Lower HOA fees.

Lower cost of development.

Lower HOA fees.

No lawsuit incentive.

Meanwhile . . .

Bungalow Courts were being demolished throughout L.A. for higher-density projects



Bungalow Courts were being demolished throughout L.A. for higher-density projects



**And Civic Enterprise was looking
for its next project.**

We found it while driving around.

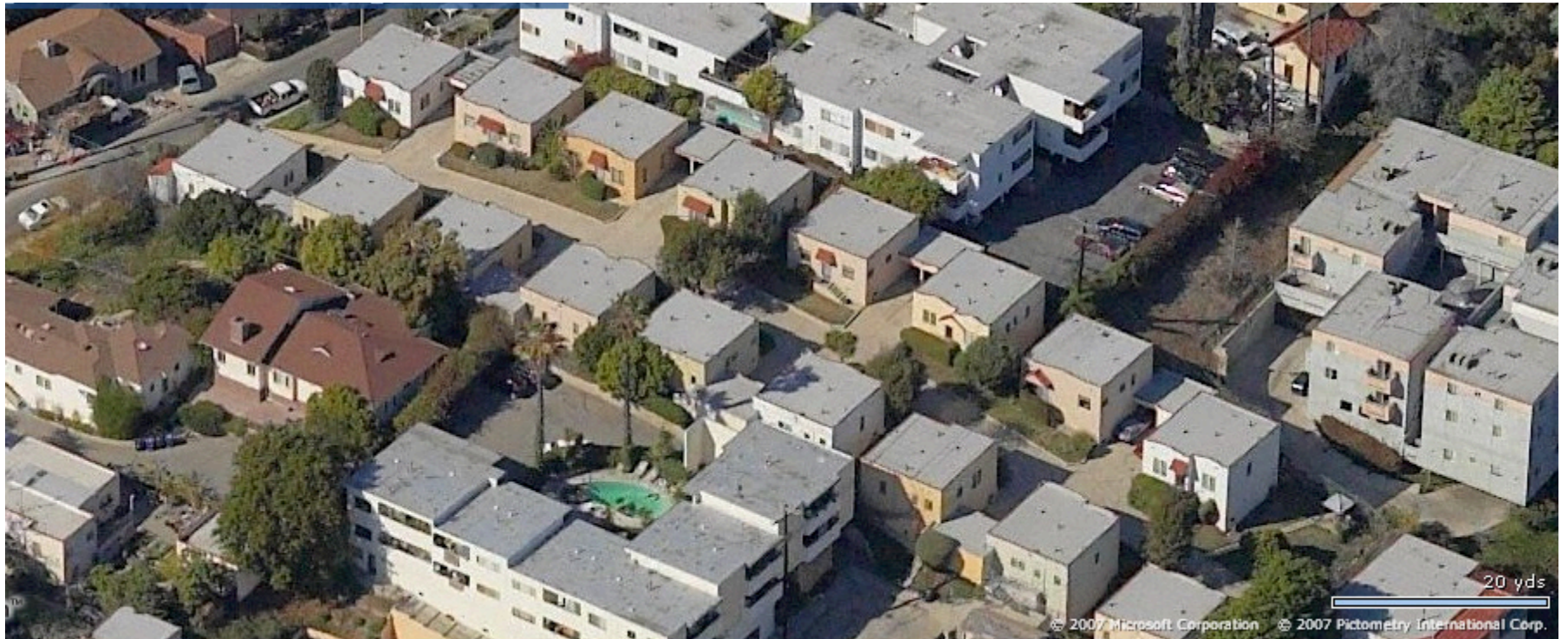

Maltman bungalows pre-renovation, surrounded by newer mid-rise construction.
(local.live.com)

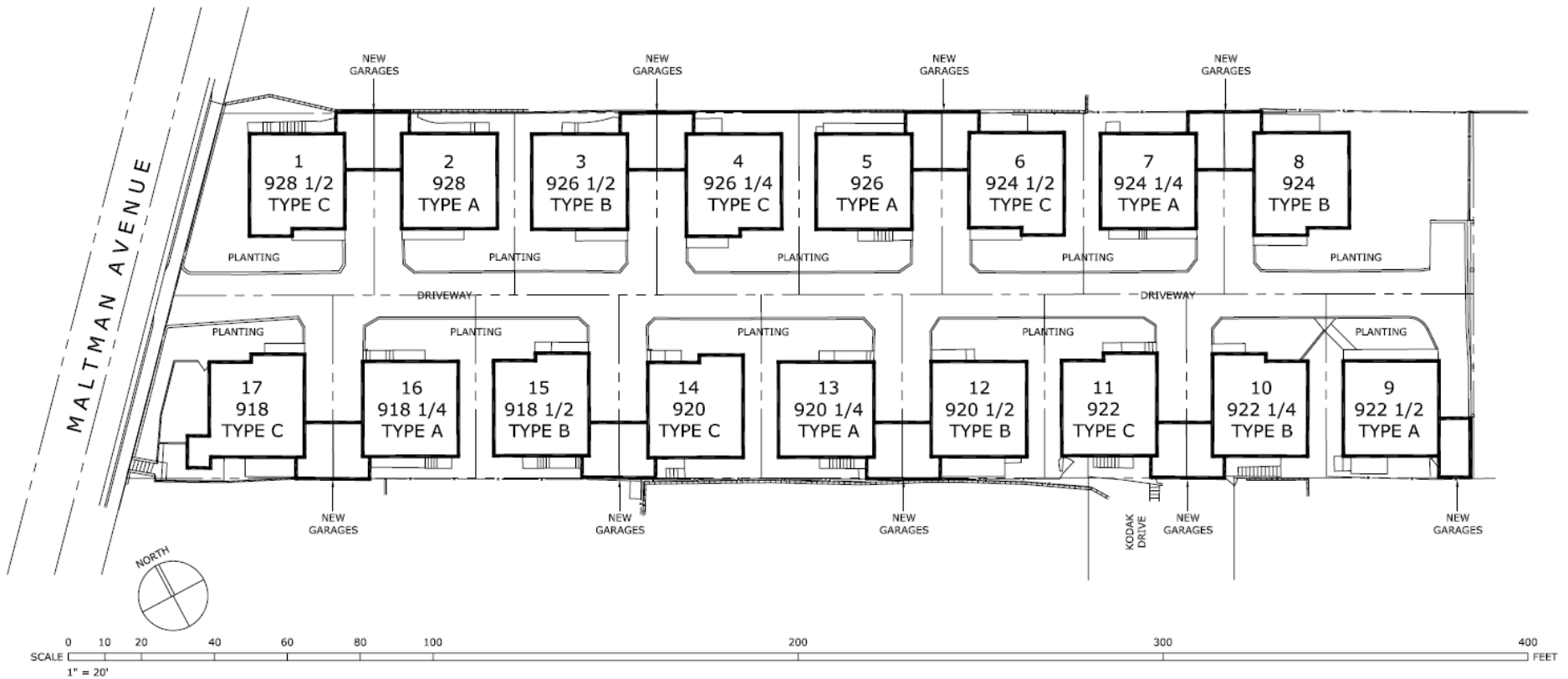

Site: 0.82 acres

Units: 17 (originally built in 1926)

Mix: 11 one-bed (~700 sq. ft.)
6 two-bed (~700 sq. ft.)

Zoning: RD2



Looking west towards Maltman Avenue along central driveway just prior to construction.



One of the bungalows prior to renovation.



Original attached garages prior to renovation.



Typical bathroom prior to renovation.



Typical kitchen and utility room prior to renovation.



The Wisehaupt children in the 1940s. The Wisehaupt family owned the Maltman Bungalows from 1935 through 2007. (Photo courtesy of Harold Wisehaupt)



1949 - Jan

Photo courtesy of Harold Wisehaupt

Our goals:

1. Subdivide Maltman Bungalows as SFRs

Our goals:

1. Subdivide Maltman Bungalows as SFRs
2. Restore units' historic character

Our goals:

1. Subdivide Maltman Bungalows as SFRs
2. Restore units' historic character
3. **Sell below current entry-level pricing**



Montage of bungalows during renovation.



Unsalvageable wooden windows and doors were documented and replaced with custom reproductions. Nearly all original hardware was restored.



Original garage rooflines were documented and reproduced in new construction. Note 6" air gap between the rebuilt structures.



Paint colors were chosen from a period-appropriate palette.



Floor Plan C

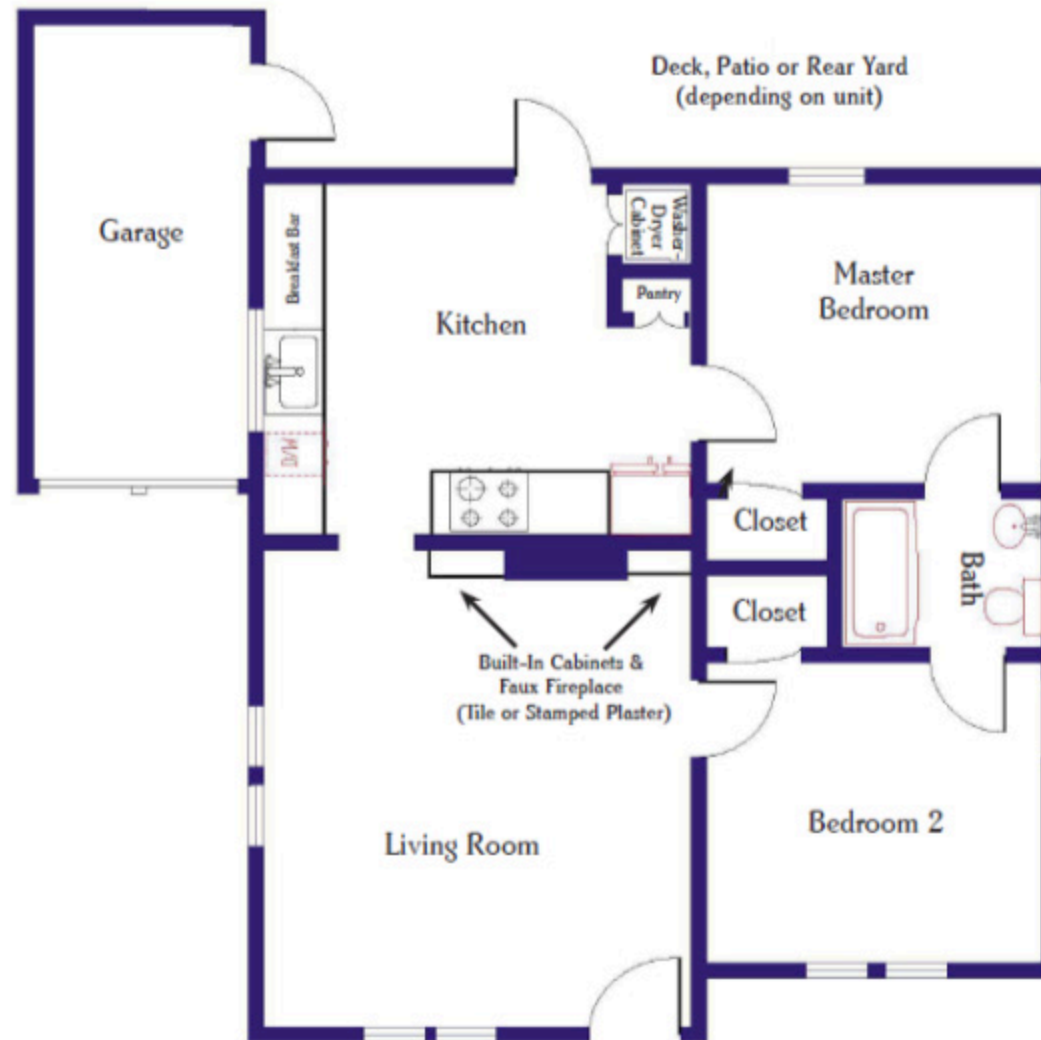



Photos by Axel Koester

Results

- **Preserved a classic bungalow court**

Results

- Preserved a classic bungalow court
- **Created 17 new first-time homeowner households** (including three former tenant households)

Results

- Preserved a classic bungalow court
- Created 17 new first-time homeowner households (including three former tenant households)
- **Demonstrated market for compact units**

Results

- Preserved a classic bungalow court
- Created 17 new first-time homeowner households (including three former tenant households)
- Demonstrated market for compact units
- **Helped work through some regulatory issues for small lot projects**

Thank You